

EUROPA HANDBRAKE ADJUSTMENT MODIFICATION

Does it seem that as soon as you adjust the handbrake cable on your Europa it is out of adjustment again? If so then you are having the same problem that a number of Twin Cam Europa owners have had. There is a solution. In fact, a factory suggested modification can greatly ease the problem. This modification results in increasing the maximum travel distance of the handbrake. It's very simple and I've even explained it in much greater detail than needed.

Disconnect the handbrake cable from under the dash, where it attaches to the pivot lever from the hand pull. This is done with the handbrake released.

Now, while you're under the dash, remove the handbrake assembly so that it may be modified. Carefully look at the drawing, below, and at the unit in your hand. The drawing is of the end that was hidden under the dash. Locate the cut-off point, as indicated. This is perpendicular to the barrel of the handbrake assembly. Cut off the end of the barrel at this point. File and/or sand smooth the burrs from cutting the barrel. Discard the cut off piece.

Replace the assembly under the dash and attach the cable. Adjust the cable, if necessary.

View of end of assembly to be modified.

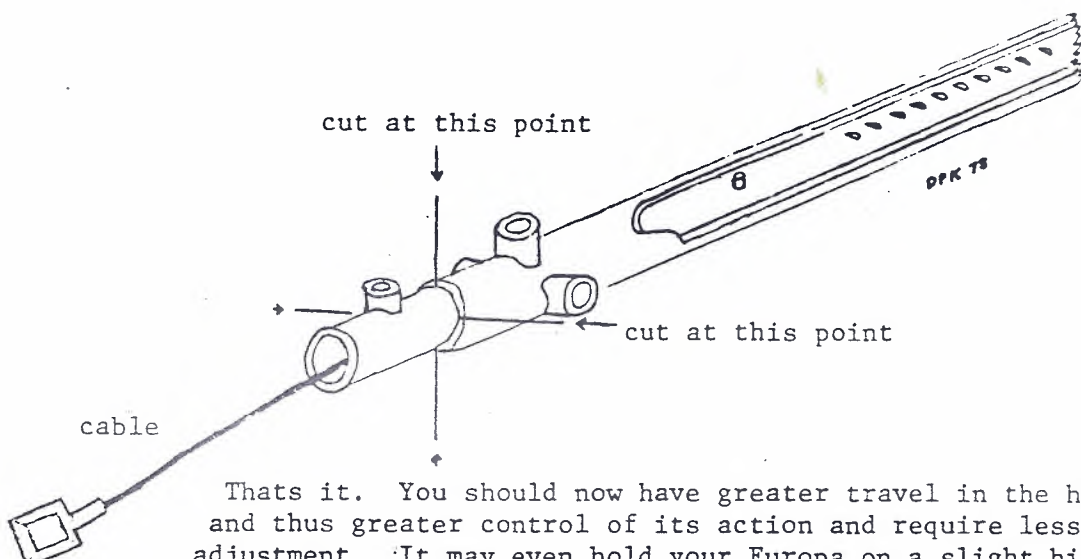

That's it. You should now have greater travel in the handbrake and thus greater control of its action and require less frequent adjustment. It may even hold your Europa on a slight hill for a change.

David Krivoshik
Elizabeth, N.J.